

MaxMotion

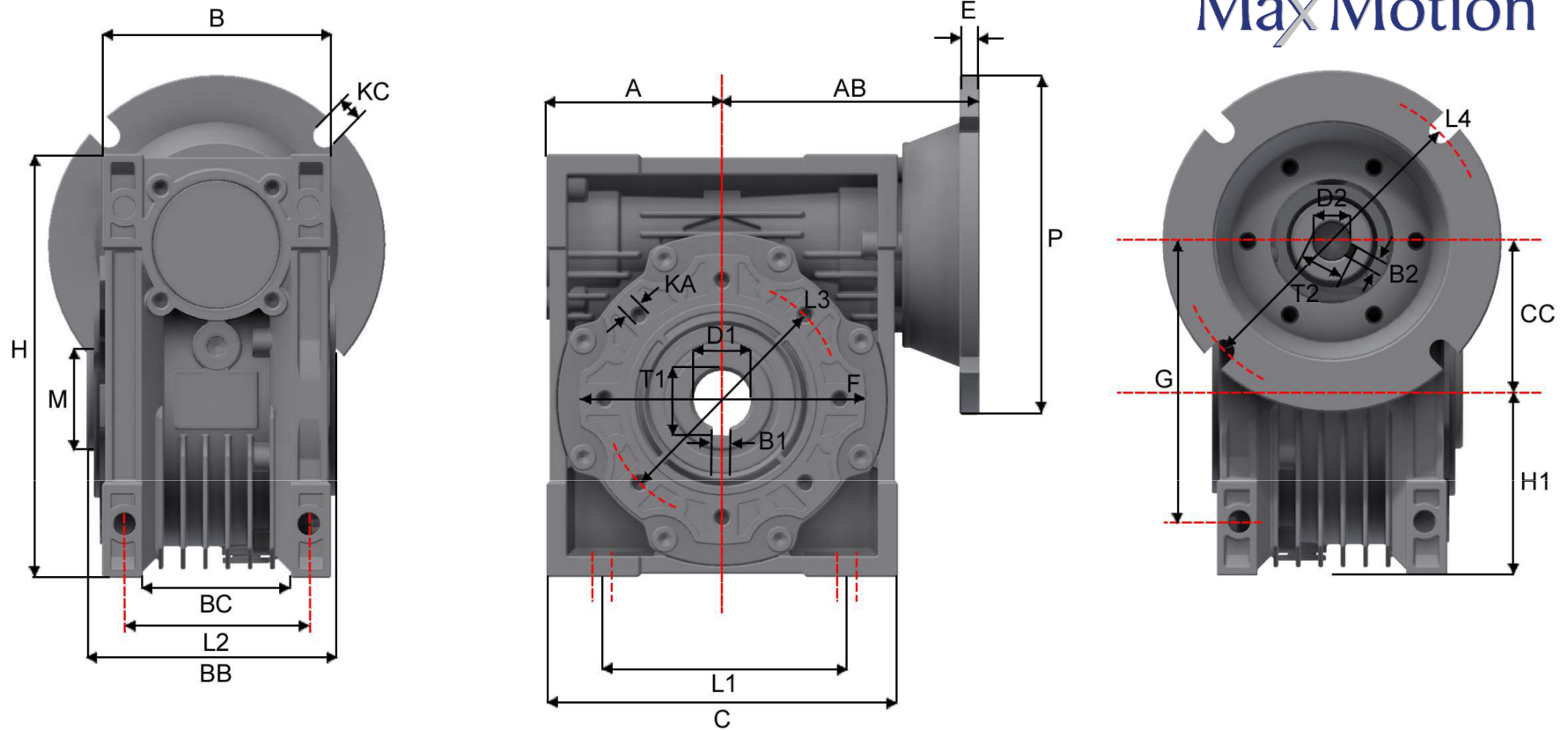

Version: 1HAN		Revised: 01-05-2020		Worm Gear Right 90° Angle Gearbox				MMR90-56C						
Customer is responsible in determining that MEP product will fit/perform suitably in the intended application														
A	B	C	E	F	G	H	M	P	B1	B2	D1	D2	H1	
103	134	208	5	160	160	238	110h8	∅165	7.94 ± 0.18	4.76 +0.078/0.03	∅34.925H7 +0.025	15.87 +0.059/0.032	103	
L1	L2	L3	L4	T1	T2	AB	BB	BC	CC	KA	KC			
140	100	130	∅149.35	38.56 +0.25	18.3 +0.10/-0.0	129.50	140	74	90	M10 X 18	11			

RIGHT ANGLE SPEED REDUCER

ALUMINUM CONSTRUCTION



DIMENSION DESIGNATIONS:

BACK VIEW	
H	Height of gearbox casing.
M	Outer diameter of output hollow shaft sleeve lip.
B	Width of gearbox casing
KC	Hole slot size in input flange for motor mounting.
BC	Inside distance between side mounting feet.
L2	Center distance between feet mounting holes.
BB	Width of gearbox casing + lip of hollow shaft sleeve seat.
SIDE VIEW	
A	Horizontal distance from the center of hollow output shaft to the side of the gearbox casing.
AB	Horizontal distance from the center of hollow output shaft to the outside of the front motor mounting input flange.
E	Input mounting flange thickness.
P	Outer diameter of input motor mounting flange.
L1	Center distance between feet mounting holes.
C	Width of gearbox casing.
KA	Hole size for mounting optional output flange or torque arm.
L3	Bolt circle for mounting optional output flange or torque arm.
F	External width of mounting provisions for optional output flange.
D1	Output shaft diameter.
B1	Width of the output shaft key.
T1	Hollow output shaft diameter + 1/2 key.
FRONT VIEW	
G	Center distance between hollow input shaft and side mounting holes.
L4	Bolt circle in input motor mounting flange.
CC	Center distance between input & output shafts. (Input & output gears).
H1	Height to the center of the output shaft.
D2	Input shaft diameter.
B2	Width of the input shaft key.
T2	Hollow input shaft diameter + 1/2 key.